

NOVALINE[®] FASCIA SYSTEM

INSTALLATION GUIDE

LYSAGHT



LYSAGHT NOVALINE® FASCIA SYSTEM

NOVALINE® fascia system is compatible with most of our popular LYSAGHT® gutters, including QUAD 115 & 150 Hi-Front & Lo-Front and TRIMLINE®.

Compatible LYSAGHT® gutters in South Australia include SHEERLINE®, OGEE® and QUAD 115 Hi-Front (D gutter).

MATERIAL SPECIFICATIONS

Next generation ZINCALUME® aluminium/zinc/magnesium alloy coated steel complies with AS1397:2011 G550, AM125 (550 MPa minimum yield stress, 125g/m² minimum coating mass).

COLORBOND® steel is a pre-painted steel product for exterior roofing and walling. The painting complies with AS/NZS 2728:2013 and the steel base is an aluminium/zinc/magnesium

alloy coated steel complying with AS 1397:2011. Minimum yield strengths are G550 (550 MPa).

LENGTHS

NOVALINE® fascia is supplied custom cut.

NOTE: The NOVALINE® rebate fascia system is supplied in Western Australia only.

INSTALLATION

SUPPORT SPACINGS

The NOVALINE® fascia should be supported on fascia brackets attached to rafters at 1200mm (maximum centres). The NOVALINE® fascia should not be used as an end span support.

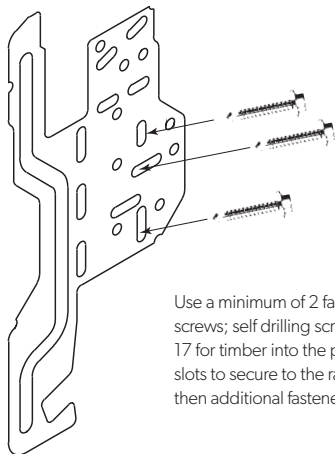

Use a minimum of 2 fasteners (Hex Head screws; self drilling screw for steel, or Type 17 for timber into the pre-punched holes and slots to secure to the rafter. If slots are used then additional fasteners may be required.

FASCIA INSTALLATION

STEP 1: Attach rafter fascia bracket at each end of the run, then run a stringline from end to end of the run. Attach one or two rafter brackets at mid-region of the run, level and in line with the string line.



STEP 2: Hook the fascia horizontally under each fascia bracket, then flip the fascia forward and lever over the top of the bracket into the vertical position.

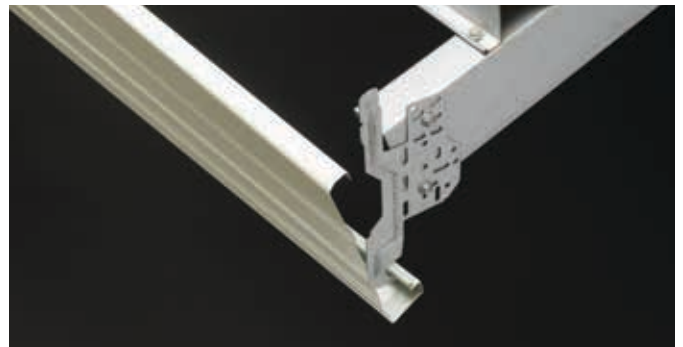

STEP 3: Adjust the fascia to the correct position by sliding it along the brackets, then secure the remainder of the intermediate brackets by twisting into fascia first, and then connecting to the rafters.



STEP 4: Fit the fascia accessories as required. (i.e. corners, end closers, etc.)

GUTTER INSTALLATION

The following steps describing gutter installation is a suitable process where there is only a single installer. The gutter installation process can be varied to suit the local practices and the number of available installers, however the basic principles described in the following steps should be maintained.

STEP 1: Straddle the spring clip over the fascia by rolling from behind and up over the fascia to the vertical position. Position all the clips along the length of the fascia in preparation for gutter installation. Do not fully engage the spring clips until ready for the gutter installation. (Refer to Step 3).



Step 1: Preparing to attach spring clip

STEP 2: Place two spring clips a maximum of 1200mm apart over the fascia at the mid-point position of the length of the gutter about to be installed. Push the spring clip all the way down into place.



You can push down by hitting the top of the clip with a closed fist.

Step 2: Final position of spring clip

STEP 3: By holding the gutter from underneath, and pushing down on the spring clip, push the gutter up between the fascia and the spring clip.

Temporarily push the gutter up so that the top zinger (rib) of the gutter is placed between the lower two barbs of the spring clip. Longitudinally slide the gutter to the correct alignment.

STEP 4: Push all remaining spring clips down into position (Step 2) and temporarily push the gutter into spring clips (Step 3).

STEP 5: When working your way down from the high end to the low end, push down onto the spring clip over the fascia and, then push the gutter back up to the desired level (refer General Note 3) to retain a fall of 1 in 500 (min).

STEP 6: Locate the appropriate gutter overstrap by engaging under the front of the gutter scroll, then roll the rear of the overstrap back towards the fascia.

Ensure the heel of the overstrap does not bear onto the gutter zinger.

Secure the overstrap by folding the tail behind the fascia.



Step 3: Attaching the gutter overstrap

GENERAL NOTES:

1. The clips are to be located beside a NOVALINE® fascia bracket at 1200mm (maximum) centres and sit firmly on top of the fascia
2. Unless specifically noted otherwise, the overstraps can be located beside the clips/fascia bracket assembly, or mid-way between the clips, at 1200mm (maximum) centres. The decision on the location of the overstraps should be made based on local installer practices and the overall preferred aesthetics of the installation
3. The highest barb setting of the gutter engagement into the clip will be governed by the clip design, zinger location and overstrap installation (see step 6)
4. For any gutter run, the gutter setting within the spring clips from high point to low point (downpipe location) there must be at least two barbs difference
5. A maximum spacing of 12m between downpipes (in accordance with BCA requirements) should be maintained
6. When a gutter end abuts a wall or fascia then a gap should be provided

IMPORTANT NOTICE:

1. Where high-fronted gutters are installed, the BCA (and AS/NZS 3500.3) require that provision must be made to avoid any overflow back into the roof or building structure. It is the responsibility of designers and installers of roof drainage systems to ensure compliance with these requirements
2. There are many options available to the roof drainage system designer. For further information, please refer to your local Rainwater Solutions brochure available at www.lysaght.com
3. Roof drainage systems must be regularly cleaned and maintained in order to handle overflow by ensuring free drainage of water

LYSAGHT NOVALINE® FASCIA SYSTEM

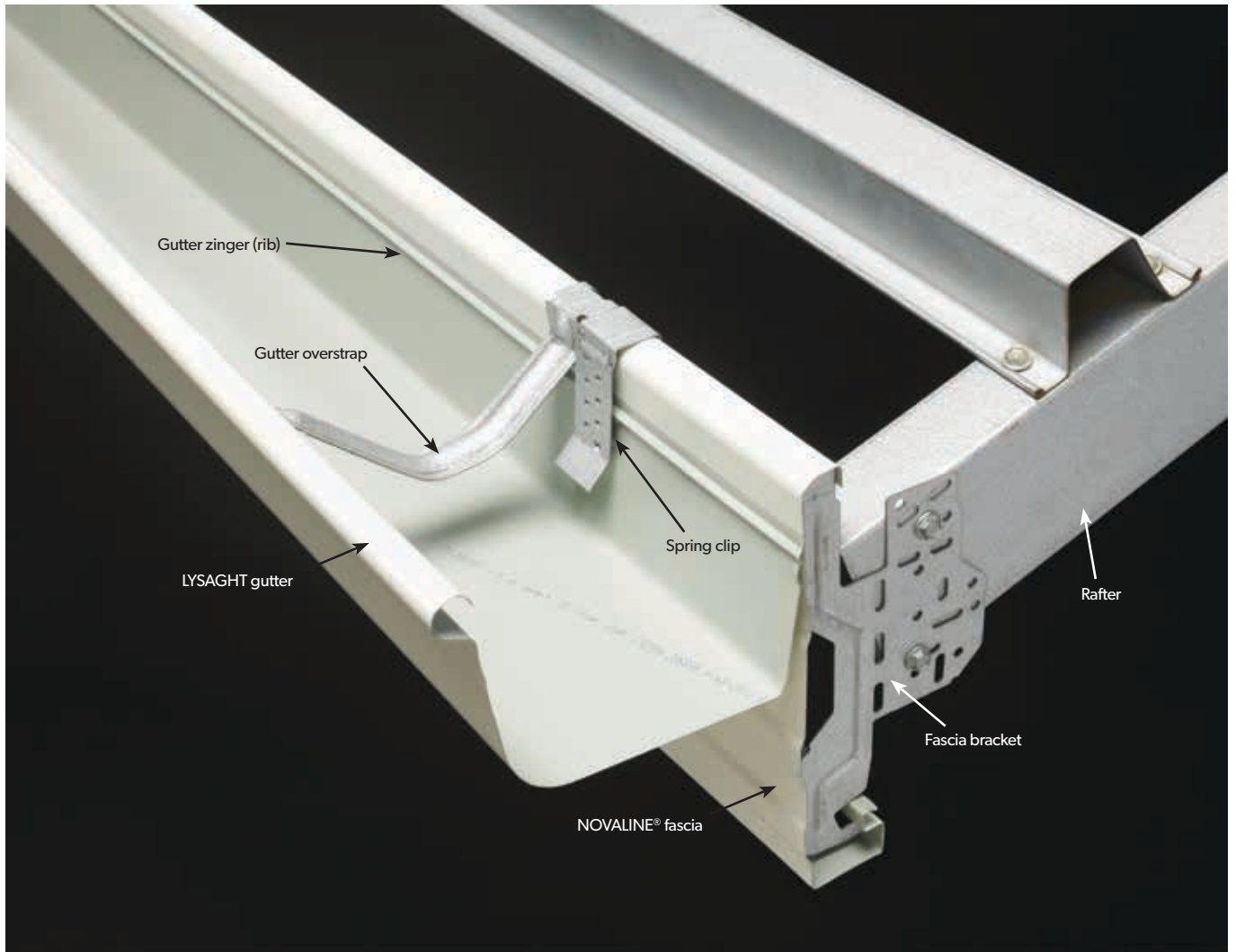

AVAILABILITY

The NOVALINE® fascia system is available in most states, though the West Australian product has a different (rebated) profile. For product availability in your area, discuss with your local Lysaght branch.

FINISHES

COLORBOND® steel colours.

ADVERSE CONDITIONS

If these products are to be used within 1km of marine, severe industrial, or unusually corrosive environments, ask for advice from our information line.

STORAGE AND HANDLING

Keep the product dry and clear of the ground. If stacked or bundled product becomes wet, separate it, wipe it with a clean cloth and stack it to dry thoroughly.

Handle materials carefully to avoid damage: don't drag materials over rough surfaces or each other; carry tools, don't drag them, protect from swarf.

CLEAN UP

Remove all plastic cover strips from product and dispose of correctly.

Sweep all metallic swarf and other debris from roof areas, gutters, downpipes, overflow devices and all other roof drainage components, at the end of each day and at the completion of the installation.

Failure to do so can lead to blockages of water flow or surface staining (such as when the metal particles rust).

MAINTENANCE

The roof drainage system (gutter, downpipes, overflow devices and all other components) must be cleaned out on a regular basis. Refer to the regional Rainwater Solutions brochure.

LYSAGHT NOVALINE® FASCIA SYSTEM

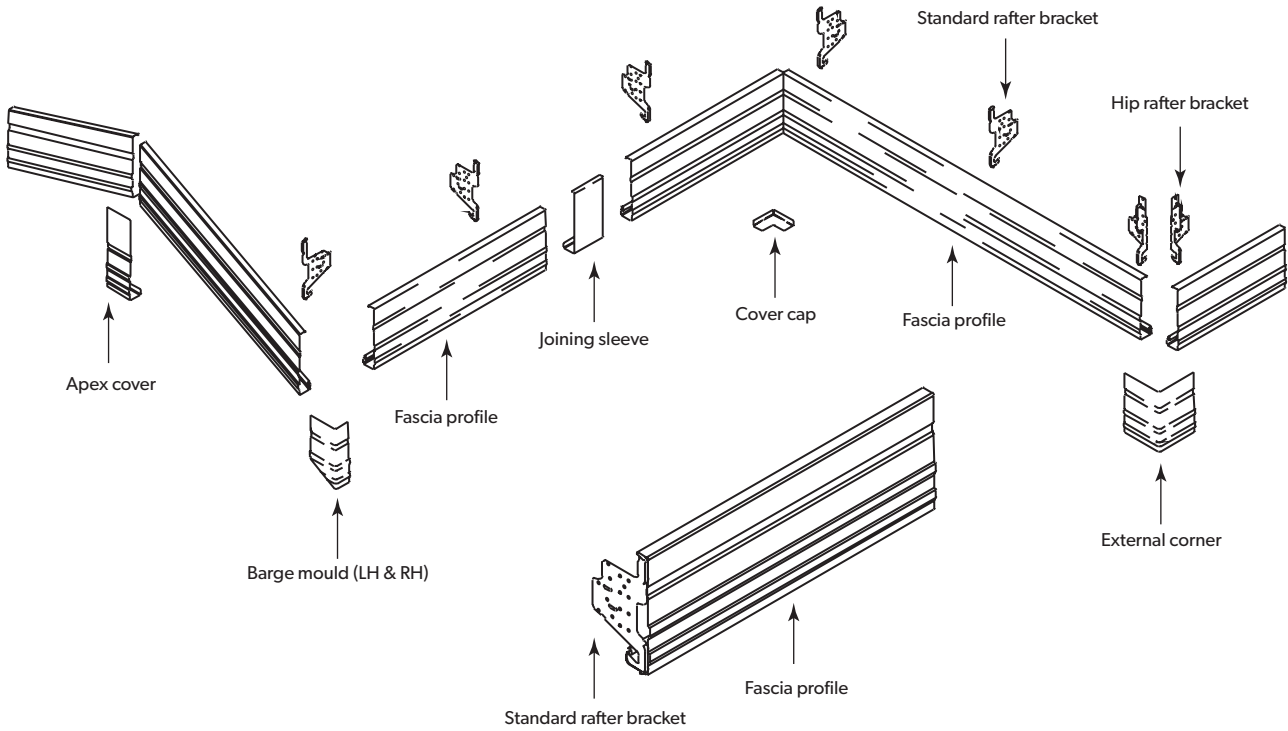

LYSAGHT NOVALINE® FASCIA ACCESSORIES

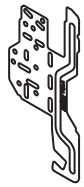
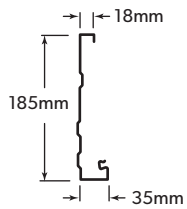

Multi purpose fascia bracket



Hip bracket



Spring clip

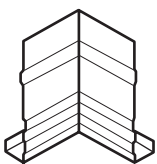

Internal corner

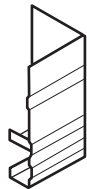

External corner

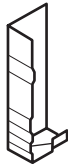

Barge mould right hand

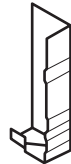

Barge mould left hand



Splice plate

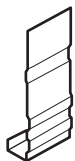

Apex cover



End closer

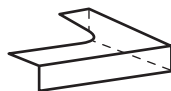

Internal cover cap

PRODUCT DESCRIPTIONS

- All descriptions, specifications, illustrations, drawings, data, dimensions and weights contained in this catalogue, all technical literature and websites containing information from Lysaght are approximations only. They are intended by Lysaght to be a general description for information and identification purposes and do not create a sale by description. Lysaght reserves the right at any time to:

(a) supply Goods with such minor modifications from its drawings and specifications as it sees fit; and
(b) alter specifications shown in its promotional literature to reflect changes made after the date of such publication.

DISCLAIMER, WARRANTIES AND LIMITATION OF LIABILITY

- This publication is intended to be an aid for all trades and professionals involved with specifying and installing Lysaght products and not to be a substitute for professional judgement.
- Terms and conditions of sale available at local Lysaght sales offices.
- Except to the extent to which liability may not lawfully be excluded or limited, BlueScope Steel Limited will not be under or incur any liability to you for any direct or indirect loss or damage (including, without limitation, consequential loss or damage such as loss of profit or anticipated profit, loss of use, damage to goodwill and loss due to delay) however caused (including, without limitation, breach of contract, negligence and/or breach of statute), which you may suffer or incur in connection with this publication.

© Copyright BlueScope Steel Limited 14 May, 2015

WWW.LYSAGHT.COM

Technical enquiries:
steeldirect@bluescopesteel.com or call 1800 641 417

LYSAGHT®, NOVALINE®, OGEE®, TRIMLINE®, SHEERLINE®, COLORBOND® and ZINCALUME® are registered trademarks of BlueScope Steel Limited, ABN 16 000 011 058. The LYSAGHT® range of products is exclusively made by or for BlueScope Steel Limited trading as Lysaght.

